

THE PURPOSE OF THE USPAP IS TO PROMOTE TRUST.

THIS IS A PRINCIPLE-DRIVEN PROCESS.



信言

PHILIP B. CROSBY

Author of the best-selling
Quality Is Free

More than
400,000 sold

**QUALITY
WITHOUT
TEARS**

*The Art of
Hassle-Free Management*

*14 Steps to "Zero-Defect" Improvement
From "The Leading Evangelist of Quality
in the U.S."—Time*

Mr. Crosby proposes the following simple three-step solution to the problem of quality assurance.

Here they are:

1. Establish a quality standard
2. Get agreement to follow the standard from everyone in your organization
3. Always adhere to your quality standard. Always.

Unimportant Violations



IF YOU DO NOT HAVE TIME TO DO IT RIGHT...

WHEN WILL YOU HAVE TIME TO DO IT OVER?



DESIGN FLAW

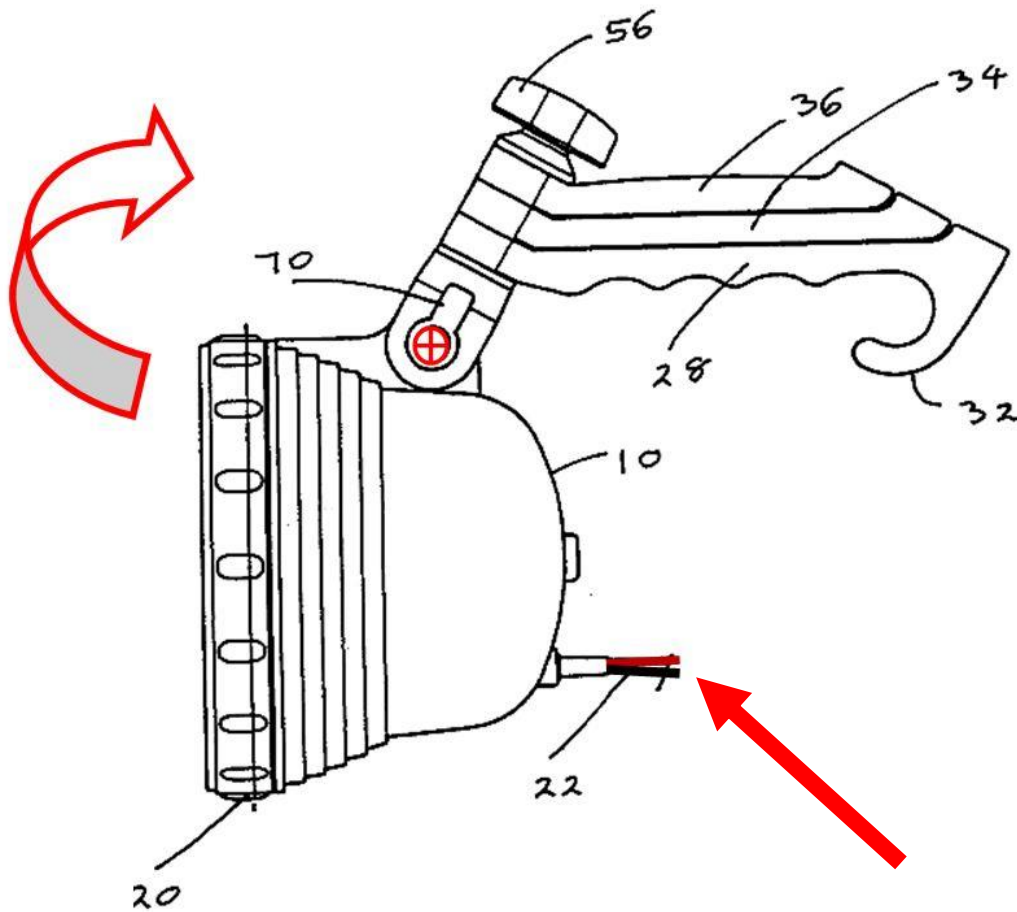

FIG. 7

This is the drawing submitted to the U. S. Patent Office – Notice that the length of wires is not shown

FIRREA AND THE CREATION OF THE USPAP

Compare these benchmark events with the recommendations at the core concepts presented in Quality without Tears:

- **ESTABLISH A QUALITY STANDARD**
- **GET AGREEMENT TO FOLLOW THE STANDARD**
- **ADHERE TO THE QUALITY STANDARD**

CHECKLISTS

THE NEW YORK TIMES BESTSELLER

THE CHECKLIST MANIFESTO

HOW TO GET THINGS RIGHT



PICADOR

ATUL GAWANDE

BESTSELLING AUTHOR OF *BETTER AND COMPLICATIONS*